

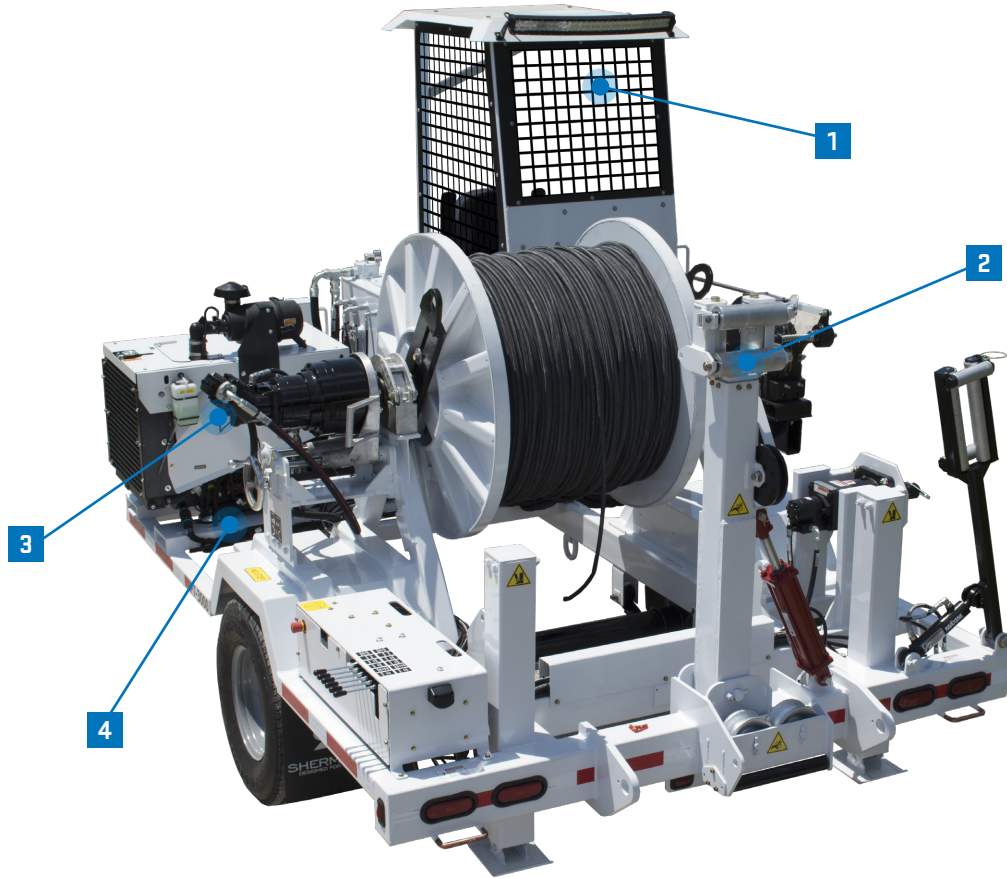

SHERMAN+REILLY®

PT-3000 PULLER TENSIONER

3,000 LBS. SINGLE DRUM PULLER TENSIONER



- 1 Wrap-around cab enclosure with LED light bar
- 2 Dual overhead and underground hydraulic levelwind
- 3 Direct drive hydrostatic motor
- 4 Mechanical spline engagement system

FEATURES

- Puller, tensioner, and reconductor in single unit
- Provides unmatched versatility as a puller or tensioner for overhead or underground applications
- Capable of pulling 3,000 lbs. and tensioning 2,000 lbs.
- Compact footprint with a 16 ft. single axle, dual tire configuration
- A broad suite of options allows customers to configure their unit to their specific needs
- Equipped with CANbus technology and real-time self-diagnostics

PT-3000 PULLER TENSIONER

3,000 LBS. SINGLE DRUM PULLER TENSIONER

Sherman-Reilly.com

SPECIFICATIONS

Pulling Capacity:	3,000 lbs. (Rated at top of 46 in. drum) Max: 3,300 lbs. (Rated maximum)
Tensioning Capacity:	2,000 lbs.
Maximum Line Speed:	Pulling: 4 mph
Maximum Conductor Reel Size:	66 in. diameter/40 in. width
Maximum Conductor Reel Weight:	Dynamic - Over the Road - w/PMTA 3,200 lbs., w/o PMTA 4,000 lbs. Static - Jacks Extended - 6,000 lbs.
Drum Dimensions:	Core Diameter: 18 in. Total Outside Width: 40 in. Flange Diameter: 46 in.
Drum Capacity:	11 mm. dia. Unirex™ 17,000 ft. 5/8 in. dia. Uniline™ 8,450 ft. Standard rope length is 6,000 ft. of 5/8 in. Uniline
Drive System:	Direct Drive: single hydraulic motor, drum and drive bar/dual pin
Drive System Engine:	Turbocharged, Tier-4 Final, diesel, 45 Hp, water-cooled
Fuel Capacity:	13 Gallon
Hydraulic Fluid:	ISO Grade 32
Hydraulic Reservoir:	25 Gallon
Hydraulic Fluid Filtration:	10 micron, both supply and return filters
Levelwind:	Hydraulically driven, manually controlled
Operator's Safety Enclosure:	Open cab enclosure
Frame Construction:	Steel tubing, Steel plate, continuous weld
Length: (Overall, Nom.)	18 ft., 11 in.
Width: (Overall, Nom.)	8 ft., 6 in.
Height: (Overall, Nom.)	9 ft., 6 in.
Weight*:	9,400 lbs.
GVWR:	11,000 lbs.
Suspension:	Leaf-spring
Axle Configuration:	Single
Wheel Configuration & Tires:	Dual 235/85R 16 LRE; 8-6.5
Brakes: (Trailer)	Electric, with break-away switch
Towing Attachment:	3 in. pintle eye, with two safety chains and hooks
Tie Downs:	5/8 in. dia. Steel D-Rings (2)
Tie Off Points:	Tie off point at bumper, 3000 lbs. working load limit
Rear (R/L) Jacks:	(2) Hydraulic, with shoe
Front/Nose Jack:	(1) Hydraulic with shoe

Electrical System:	12 VDC
Battery:	12 V 840 CCA, BCI group 27
Lights / Navigation:	US DOT, LED, 12 VDC
Grounding:	3/4 in. dia. Copper-clad Steel ground loops (4)
Wheel Chocks:	Standard
Fire Extinguisher:	ABC
Color:	S+R White
Overhead Drum Core	18 in. / Width 30 in. / Flange 46 in.
Underground Drum Core	12.75 in. / Width 31.75 in. / Flange 24 in.

OPTIONS

Hydraulic Pad Mount Transformer Attachment capable of 7,500 lbs maximum working load
RCR-60: Core: 24 in. to 18 in. tapered Total Outside Width: 39 in. (Flange Diameter: 60 in.)
Underground levelwind for pulling underground
Spider® Pilot Line System with independent levelwind S-75 or S-85 spider reels with 3,000 ft. or 6,000 ft.
RDG-2100 Rotating Distribution Ground
DG-4100 Running Ground
Underground Option with UG Drum 24 in. OD, 31.75 in. W, 3/8 in. x 2,000 ft., 6x25 IWRC
E-35 Underground Swivel (3,500 lbs.)
E-49 Underground Swivel (8,000 lbs.)
Solar Battery Charger



PT-3000 Control Panel

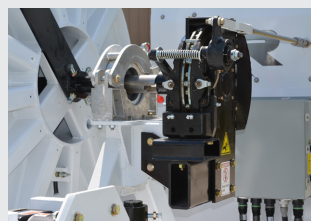

Cab operated 16 in. payout brake



Spider® Pilot Line System with independent levelwind

Unirex™ is a trademark of Unirex, Ltd. Uniline™ is a trademark of IMA NORTH AMERICA, INC.

© 2018 SHERMAN + REILLY, INC.
REV. 02/19

*Subject to change